



WM650 SERIES  
INDUSTRIAL SMALL TOP  
LOADING WASHING MACHINE



**COMPACT  
DESIGN**



**DETAILED  
CLEANING**



**MINIMUM  
CONSUMPTION**



**TECHNICAL  
SERVICE**



WM SERIES

7

	WM650	WM650-L
Basket Diameter ( mm )	550	550
Loading Height ( mm )	250	350
Loading Capacity ( kg )	150	150
Tank Capacity ( L )	60	60
Pump Pressure ( bar )	2,5	2,5
Pump Capacity ( L / min )	200 - 220	200 - 220
Pump Quantity and Power	1 pc. x 3,0 Hp	1 pc. x 3,0 Hp
Heater ( kW )	4,5	4,5
Electricity ( V / Phase / Hz )	220 - 380 - 415 / 1 - 3 / 50 - 60	220 - 380 - 415 / 1 - 3 / 50 - 60
Process Timer ( min )	0 - 90	0 - 90
Working Temperature	0 - 80°C	0 - 80°C
Rotary Basket	s	s
AISI430 Stainless Steel Material	s	s
AISI304 Stainless Steel Material	o	o
AISI316 Stainless Steel Material	o	o
Packing Size and Weight ( mm - kg )	910 x 1080 x 1150 - 180 kg	910 x 1080 x 1250 - 200 kg

s standard o optional na not available

**SPECIFICATIONS**

- Stainless Steel Body, Basket and Pipes
- Cleaning Process Timing
- Developed to save water, detergent and energy
- Minimum water consumption by closed circuit water cycling system
- Heated water (solution) dispensed through jet nozzles to the part
- High user safety on pneumatic pistons
- Belt-Pulley driven rotary table
- A water level sensor is used to protect the pumps and heaters against dry running.
- Heating elements are made of special material incoloy alloy
- European Electrical and Technical Components
- High-performance and reliable European Pump

**WORKING PRINCIPLE**

The parts which will be washed with pressured hot water and detergent mixture are placed on a rotary basket in a closed cabinet. The washing process is done through water nozzles, which are timed and compressive according to part structure, dirtiness rate; they clean the waste, oil, and chip on dirty surfaces in various angles. Machine has been designed for minimum consuming the water, detergent, electric, and time (work force) with cyclic and filtering water system.





**KSP**®

**MACHINE TOOL DIVISION**

WM850-1000-1250 SERIES  
**INDUSTRIAL TOP LOADING  
 WASHING MACHINES**



WM SERIES



**COMPACT  
 DESIGN**



**HIGH  
 PERFORMANCE**



**MINIMUM  
 CONSUMPTION**



**TECHNICAL  
 SERVICE**

	WM850	WM1000	WM1250
Basket Diameter ( mm )	750	900	1150
Loading Height ( mm )	350	450	600
Loading Capacity ( kg )	150	300	450
Tank Capacity ( L )	60	80	200
Pump Pressure ( bar )	2,5	2,5	2,5
Pump Capacity ( L / min )	200 - 220	200 - 220	200 - 220
Pump Quantity and Power	1 pc. x 3,0 Hp	1 pc. x 3,0 Hp	1 pc. x 3,0 Hp
Heater ( kW )	7,5	7,5	15
Electricity ( V / Phase / Hz )	220 - 380 - 415 / 1 - 3 / 50 - 60	220 - 380 - 415 / 1 - 3 / 50 - 60	220 - 380 - 415 / 1 - 3 / 50 - 60
Process Timer ( min )	0 - 90	0 - 90	0 - 90
Working Temperature	0 - 80°C	0 - 80°C	0 - 80°C
Loading Vehicle	na	o	s
Rotary Basket	s	s	s
Oil Skimmer	na	s	s
AISI430 Stainless Steel Material	s	s	s
AISI304 Stainless Steel Material	o	o	o
AISI316 Stainless Steel Material	o	o	o
Packing Size and Weight ( mm - kg )	1225 x 880 x 1265 - 180 kg	1360 x 1130 x 1310 - 250 kg	1570 x 1280 x 1550 - 450 kg

s standard o optional na not available





**SPECIFICATIONS**

- Stainless Steel Body, Basket and Pipes
- Cleaning Process Timing
- Developed to save water, detergent and energy
- Minimum water consumption by closed circuit water cycling system
- Heated water (solution) dispensed through jet nozzles to the part
- High user safety on pneumatic pistons
- Belt-Pulley driven rotary table
- A water level sensor is used to protect the pumps and heaters against dry running
- Heating elements are made of special material incoloy alloy
- European Electrical and Technical Components
- High-performance and reliable European Pump

**WORKING PRINCIPLE**

The parts which will be washed with pressured hot water and detergent mixture are placed on a rotary basket in a closed cabinet. The washing process is done through water nozzles, which are timed and compressive according to part structure, dirtiness rate; they clean the waste, oil, and chip on dirty surfaces in various angles. Machine has been designed for minimum consuming the water, detergent, electric, and time (work force) with cyclic and filtering water system.

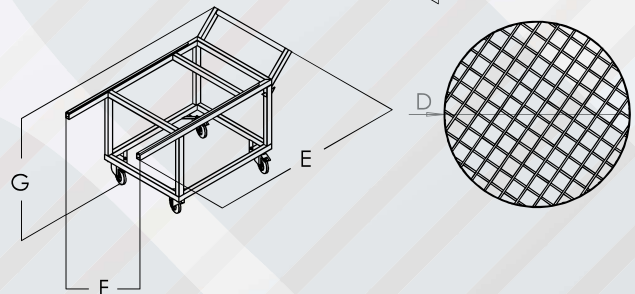
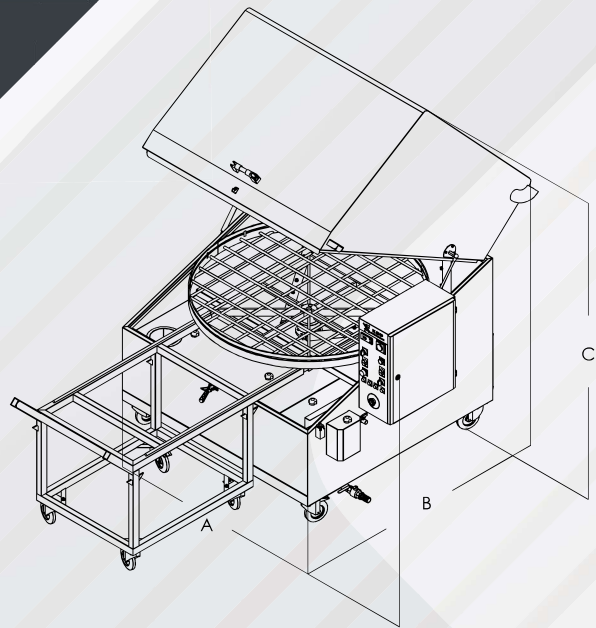

	WM850	WM1000	WM1250
A	1200	1350	1575
B	1250	1350	1550
C	1575	1750	2050
C <sub>close</sub>	1125	1170	1300
D	750	910	1150
E	X	X	1350
F	X	X	650
G	X	X	800



**KSP**®

**MACHINE TOOL DIVISION**

WM1500-1750-2000 SERIES  
**INDUSTRIAL FRONT LOADING  
 WASHING MACHINES**



WM SERIES

10



**COMPACT  
DESIGN**



**HIGH  
PERFORMANCE**



**MINIMUM  
CONSUMPTION**



**TECHNICAL  
SERVICE**

	WM1500	WM1750	WM2000
Basket Diameter ( mm )	1350	1600	1850
Loading Height ( mm )	700	800	900
Loading Capacity ( kg )	650	750	850
Tank Capacity ( L )	300	300	400
Pump Pressure ( bar )	2,5	2,5	2,5
Pump Capacity ( L / min )	200 – 220 ( Total: 400-450 )	200 – 220 ( Total: 600-650 )	200 – 220 ( Total: 600-650 )
Pump Quantity and Power	2 pcs. x 3,0 Hp	3 pcs. x 3,0 Hp	3 pcs. x 3,0 Hp
Heater ( kW )	15	15	22,5
Electricity ( V / Phase / Hz )	220 – 380 – 415 / 1 – 3 / 50 – 60	220 – 380 – 415 / 1 – 3 / 50 – 60	220 – 380 – 415 / 1 – 3 / 50 – 60
Process Timer ( min )	0 – 90	0 – 90	0 – 90
Working Temperature	0 – 80°C	0 – 80°C	0 – 80°C
Loading Vehicle	s	s	s
Rotary Basket	s	s	s
Oil Skimmer	s	s	s
Drying Unit	o	o	o
30" Precision Bag Filter System	o	o	o
30" Precision Cartridge Filter System	o	o	o
Safety Light Barrier	o	o	o
Process Height Adjustment System	o	o	o
Automatic Basket Loading System	o	o	o
Steam Extraction System	o	o	o
Mist Collector Unit	o	o	o
PLC Control and Touch-Screen	o	o	o
Water Level Control and Automatic Feeding	s	s	s
AISI430 Stainless Steel Material	s	s	s
AISI304 Stainless Steel Material	o	o	o
AISI316 Stainless Steel Material	o	o	o
Packing Size and Weight ( mm – kg )	1970 x 1610 x 2220 – 700 kg	2230 x 1990 x 2220 – 750 kg	2480 x 2210 x 2500 – 800 kg

s standard o optional na not available

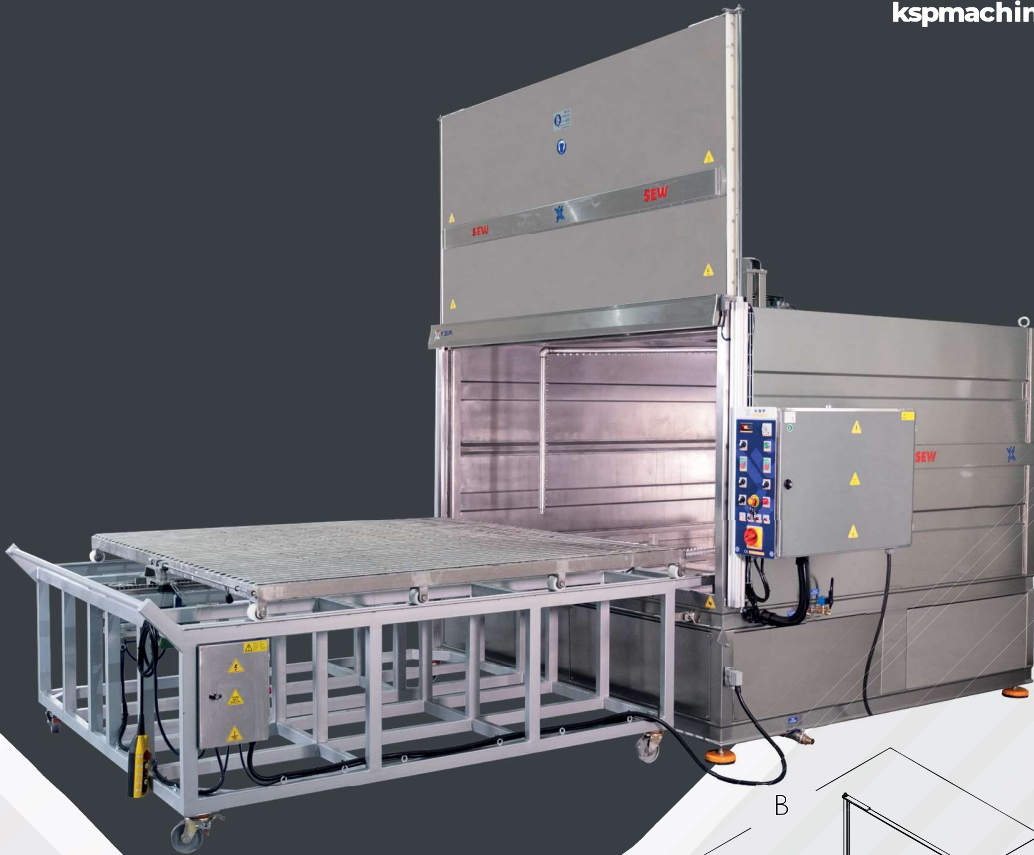

**SPECIFICATIONS**

- Stainless Steel Body, Basket and Pipes
- Cleaning Process Timing
- Developed to save water, detergent and energy
- Minimum water consumption by closed circuit water cycling system
- Heated water (solution) dispensed through jet nozzles to the part
- High user safety on pneumatic pistons
- Belt-Pulley driven rotary table
- A water level sensor is used to protect the pumps and heaters against dry running
- Heating elements are made of special material incoloy alloy
- European Electrical and Technical Components
- High-performance and reliable European Pumps
- Pneumatic Front Door System

**WORKING PRINCIPLE**

The parts which will be washed are placed on a basket that is placed on a stainless rotary platform with sliding system are washed in a closed cabinet with pressured hot water and detergent mixture. The washing process is done through water nozzles which are timed and compressive according to part structure, dirtiness rate; they clean the waste, oil, and chip on dirty surfaces in various angles. Machine has been designed for minimum consuming the water, detergent, electric, and time (work force) with cyclic and filtering water system.

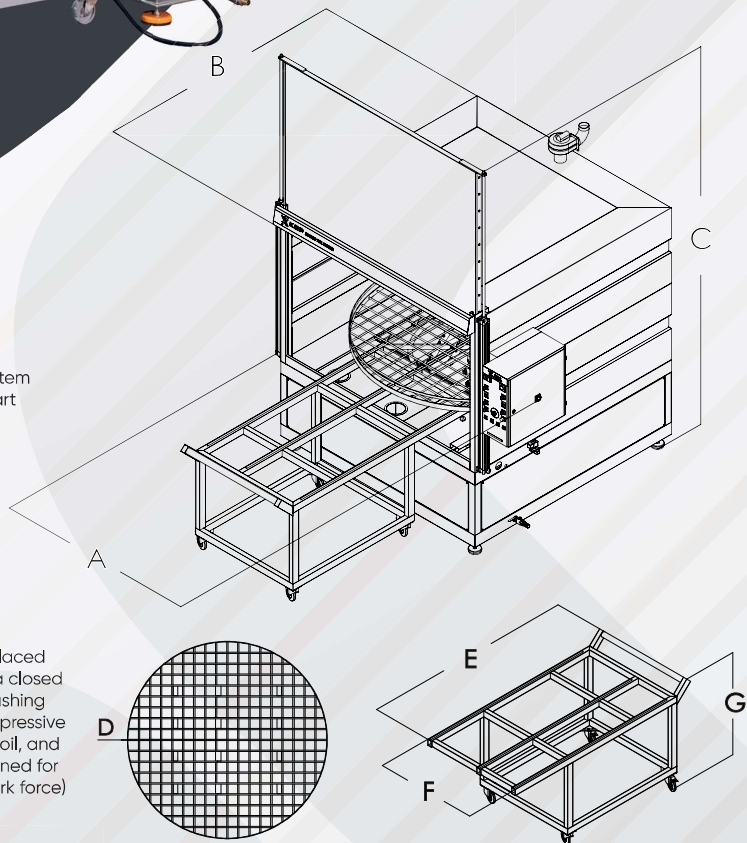

	WM1500	WM1750	WM2000
A	1950	2200	2450
B	1600	1900	2100
C	3000	3000	3475
C <sub>close</sub>	2075	2100	2375
D	1350	1600	1850
E	1500	1750	2000
F	850	850	1000
G	1000	1050	1050



WM SERIES