

C-Line

Lifting Equipment

3600



3200



Electrohydraulic underbody double scissors type lift, for tyre specialists, car workshops, and body repairers. Alignment of the runways with a dual **MASTER/SLAVE** circuit (two cylinders per runway) without mechanical safety racks. Runboards version with flaps (**F**). All models available in both on-floor and flush installation versions.



Electrohydraulic underbody double scissors type lift

SUPERLIFT 36-2XC EF
SUPERLIFT 32-2XC EF

SUPERLIFT 36-2XC EF SUPERLIFT 32-2XC EF

Electrohydraulic underbody double scissors type lift



Technical data

Model	Superlift 36-2XC EF	Superlift 32-2XC EF
<input type="checkbox"/> Lift capacity	3600 kg	3200 kg
<input type="checkbox"/> Lifting time	45 s	
<input type="checkbox"/> Three phase motor	400/230V - 3kW - 3ph - 50 / 60 Hz	
<input type="checkbox"/> Single phase motor	230V - 3kW - 1ph - 50 / 60 Hz	
<input type="checkbox"/> Max. lifting height	2040 mm	
<input type="checkbox"/> Lift minimum height	110 mm	105 mm

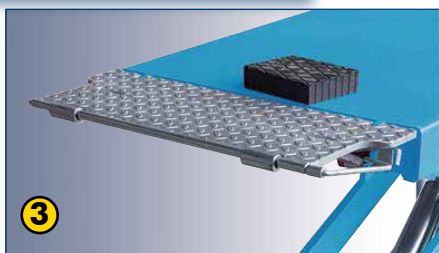

1. Unique arm geometry for maximum stiffness and minimised space usage
2. Generously sized, self-lubricating sliding blocks.
3. Runways with suspended flaps which also act as vehicle access ramps.
4. Adjustment bolts with rubber to cushion the end of the stroke
5. Special lift linkage, for lifting loads even from the lowest lift height.

Supplied accessories

All models supplied with:

- Self-lubricating bushings on all rotating parts
- Set of 4 rubber pads

Optional accessories

- Pair of cross pieces and pads for off-road vehicles.
- Kit for flush installations.

Dimensions

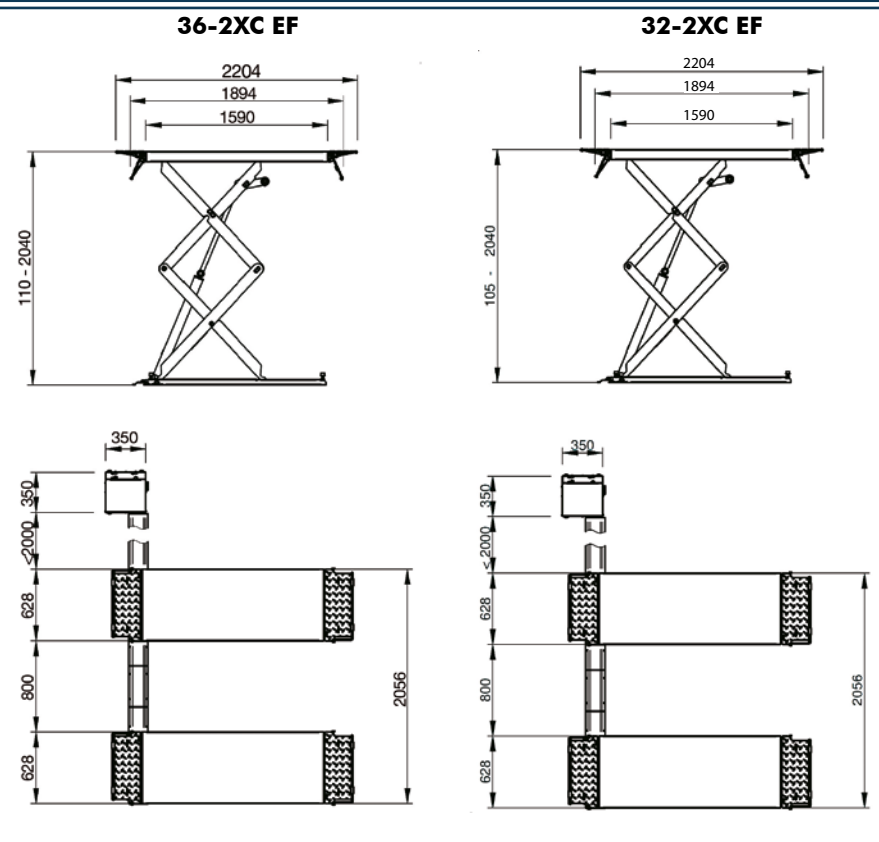

The illustrations, configurations and technical features in this publication are intended to present the product only, and are subject to variation. To ensure correct ordering, always refer to the current price list.

