

Bravo
LINE

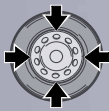

24"



*HTB24 helper a richiesta
Helper optional
code 8-11900260
Assolutamente consigliato
Absolutely recommended



LEVER-LESS
Technology

HPA
Faip



Smontagomme automatico
"LEVER-LESS technology" per
autovetture e trasporto leggero

Automatic "LEVER-LESS Technology"
tyre changer for cars
and light duty vehicles

M 54 LL



Descrizione



Description

"LEVER-LESS Technology", applicata a una torretta, che **elimina in maniera definitiva lo sforzo fisico** dell'operatore mantenendo invariati sia la procedura che i movimenti di lavoro nello smontaggio del pneumatico (**brevettato**). La procedura di montaggio mantiene invariati i movimenti, la **praticità** e la **velocità** di esecuzione.

"LEVER-LESS Technology", applied to a tool head, that **permanently eliminates operator's physical strain** while keeping both tyre demounting work procedure and movements unchanged (**Patented**). The assembly procedure movements remain the same just like its **easy-to-use** and **execution speed features**.



Dati tecnici



Technical data

<input type="checkbox"/> Presa esterna	Outside clamp	11" - 24"
<input type="checkbox"/> Presa interna	Inside clamp	13" - 26"
<input type="checkbox"/> Diametro max. ruota	Max. wheel diameter	1100 mm
<input type="checkbox"/> Larghezza pneumatico	Tire width	4" - 14"
<input type="checkbox"/> Apertura stallonatore	Bead-breaker opening	380 mm
<input type="checkbox"/> Potenza stallonatura	Bead-breaking power	15000 N
<input type="checkbox"/> Pressione di esercizio aria	Working air pressure	8 - 10 bar
<input type="checkbox"/> Potenza motore (motore a due velocità con comando a pedale)	Motor power (pedal control two speed motor)	0,85 kW - 1.1 kW
<input type="checkbox"/> Velocità rotazione mandrino	Chuck rotation speed	7 rpm - 2V 6.5 - 13 rpm
<input type="checkbox"/> Rumorosità durante il funzionamento	Noise level running	<70 dB
<input type="checkbox"/> Peso netto macchina	Nett weight machine	270 kg
<input type="checkbox"/> Peso lordo macchina	Gross weight machine	310 kg
<input type="checkbox"/> Dimensione max imballo (lpxh)	Max dimension imballage (lpxh)	1150x920x1000 mm
<input type="checkbox"/> Per contenitore da 40"	For 40" container	46 pcs

Dotazione - Equipment



Dimensioni - Dimensions

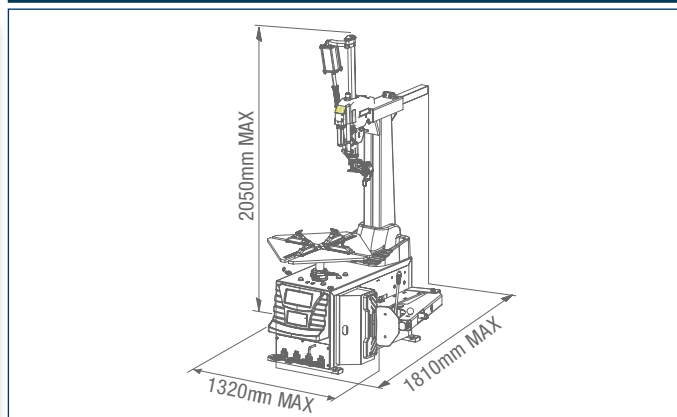

Accessori consigliati - Recommended accessories



C-M-0200000

- Adattatore motocicletta (stile rullo manuale), per uso con sistema a griffe interno regolabile
- Motorcycle adaptor (hand roller style), for inner adjustable jaws system use

CT-S-0600000

- Supporto rotazione ruota WRSB
- Wheel rotation support WRSB

8-11120075

- Sollevatore ruota FWL 65
- Wheel lifter FWL 65

Le immagini, le configurazioni e le caratteristiche tecniche riportate nel presente stampato hanno il solo scopo di presentare il prodotto e sono soggette a variazioni. Per una corretta definizione dell'ordine fare sempre riferimento al listino prezzi in vigore.
The illustrations, configurations and technical features in this publication are intended to present the product only, and are subject to variation.
To ensure correct ordering, always refer to the current price list.

NEXION S.p.A.
www.hpa-faip.it
info@hpa-faip.it

