

Sollevatori elettroidraulici a due colonne. Possibilità di installazione in versione **simmetrica** oppure **asimmetrica**.
 Riallineamento tramite funi metalliche che garantiscono un'ottima sincronizzazione dei carrelli.
 Altezza standard portale collegamento: 4.050 mm.

Disponibili nelle versioni (con set estensione colonne a richiesta):

- **V**: Alto specifico per veicoli commerciali (Altezza portale collegamento: 4.620 mm).
- **XV**: Extra alto specifico per veicoli commerciali molto alti (Altezza portale collegamento: 5.220 mm)

Electro-hydraulic two post lifts. Possibility of installation in **symmetrical** or **asymmetrical** version.
 Realignment of the two carriages using metal cables that guarantee excellent synchronisation.
 Standard height of two-post connection: 4,050 mm.

Available versions (with optional column extension set):

- **V**: Specific for vans (Height of two-post connection: 4,620 mm).
- **XV**: Specific for vans and very high vehicles, extra-high version (Height of two-post connection: 5,220 mm).

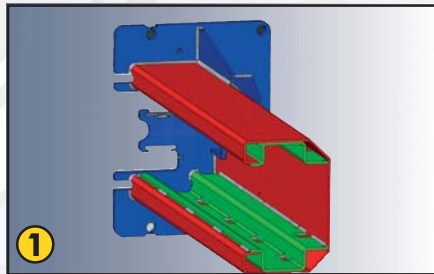

1. Struttura colonna rinforzata internamente.
Internally reinforced column structure.



5. Sblocco sicure con elettromagnete 24V
Electro magnet safety release 24V.

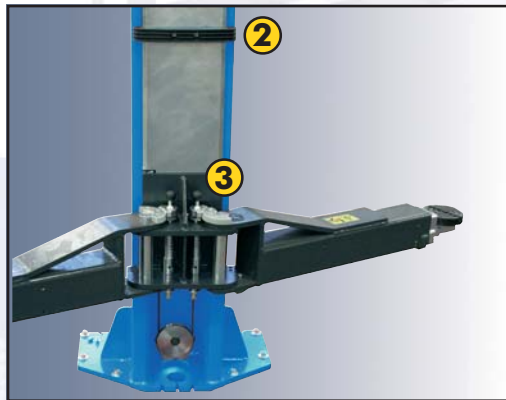

2. Protezioni in gomma salvaportiera.
Rubber door protections.

3. Arresto rotazione bracci a settori dentati
Toothed sector arm rotation stop system.



4. Quattro bracci simmetrici a 3 stadi.
Four three-section symmetrical arms.

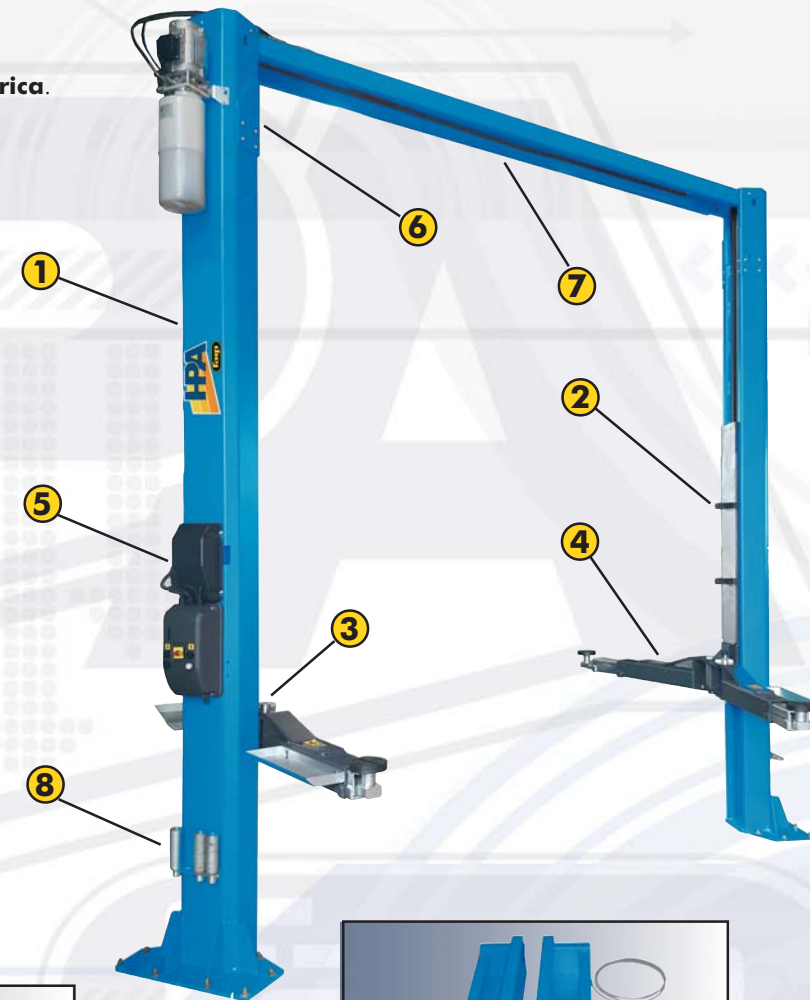

6. Set di estensione colonne (A richiesta).
Column extension set (Optional).

Dimensioni

Dimensions

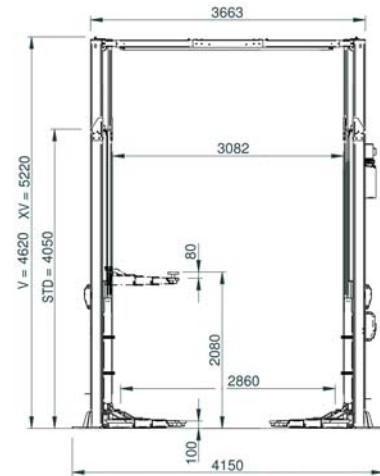

Versione asimmetrica
Asymmetric version



Versione simmetrica
Symmetrical version

Tutti modelli completi di:

- Barra superiore anticollisione fornita di serie (7).
- Due set di prolungha tamponi (8).

Accessori a richiesta:

- Set tasselli di fissaggio al suolo (obbligatorio)
- Pompa manuale di emergenza
- Set di estensione colonna L=570 mm.
- Set di estensione colonna L=1170 mm.

All models supplied with:

- Safety stop-bar included as standard (7).
- Two set of extension pads (8).

Optional accessories:

- Set of masonry bolts (compulsory).
- Emergency hand pump.
- 570 mm column extension set.
- 1170 mm column extension set.

Dati tecnici

Technical data

Modello	Model:	P2C 265C	P2C 255C	P2C 245C
<input type="checkbox"/> Portata sollevatore	Lift capacity:	6500 kg	5500 kg	4500 kg
<input type="checkbox"/> Tempo di salita	Lifting time:	45 s	45 s	45 s
<input type="checkbox"/> Motore Trifase	Three phase motor:	400/230V - 3kW - 3ph - 50/60 Hz		
<input type="checkbox"/> Motore monofase	Single phase motor:	230V - 3kW - 1ph - 50/60 Hz		
<input type="checkbox"/> Altezza max. di sollevamento	Max. lifting height:	2080 mm	2080 mm	2080 mm
<input type="checkbox"/> Altezza minima sollevatore	Lift minimum height:	100 mm	100 mm	100 mm
<input type="checkbox"/> Altezza portale	Height connection:	5220 mm	4050/4620/5520 mm	4050/4620/5520 mm

6500



5500



4500

